



Product sheet

Dinesen Layers Douglas

Dinesen Layers Douglas is a collection of engineered wooden floors in the same high quality that characterises Dinesen's classic plank floors. A Dinesen Layers floor gives you all the natural properties of a solid wooden floor in an engineered solution.

Dinesen Layers Douglas

The quality of Dinesen Layers is three-fold: the wood, the handcraftsmanship and the Dinesen know-how.

Since 1898, Dinesen has been driven by the passion to recreate the natural calm of the forest in the meeting between people and nature. Dinesen Layers Douglas is the result of craftsmanship and high-quality wood – bringing nature closer. The high-quality raw wood is sourced from European forests – primarily the Black

Forest in Germany – where forestry has been based on sustainable principles for centuries.

Every single plank is checked repeatedly throughout the Dinesen production process in the effort to deliver uncompromising quality. The planks pass through at least ten pairs of hands on their long journey through the production facilities.



Douglas Classic

- Subtle structure with a classic expression
- Harmonious and calm
- Fewer knots

Finishing and colours

Dinesen Layers Douglas planks are delivered unfinished. This allows you to choose the finish that is right for your project and your expectations for the floor.

Choose between the different nuances of oil and create your personal statement through the colour and the texture of the floor.

Dinesen Lye and Soap

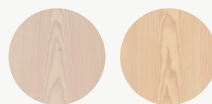

White Soap Natural Soap

Dinesen Oil

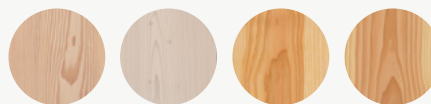

Light White Natural Invisible

Coloured Oil

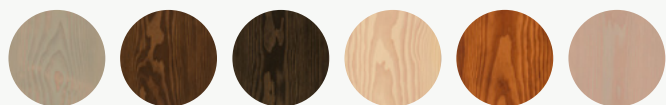

Ash Clay Graphit Sand Umbra Light Grey

- ⓘ Please note that colour differences between the floor planks, including display exhibits and samples, must be expected due to the natural characteristics of the wood. This also applies to the amount of knots and natural characteristics.

Product description

Dinesen Layers Douglas differs from other engineered floors by featuring planks made of three layers of solid wood. The top side of the plank consists of solid Douglas. The middle layer is transverse and consists of solid Douglas or finger-jointed Douglas offcuts from our production of solid planks. The underside of the plank is constructed similarly to the middle layer, and may thus vary in expression.

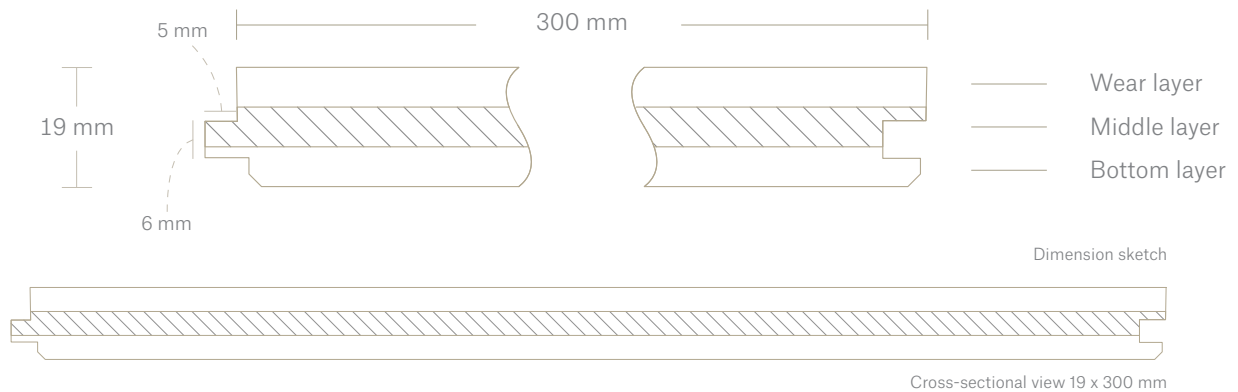

Finger-jointed lamellas

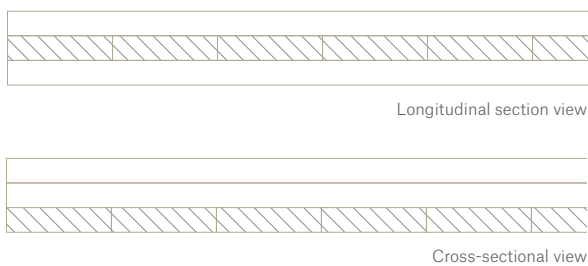

A variant where the middle and bottom layers consist of finger-assembled off cut wood from our own production, which ensures optimal utilisation of the raw material.

- Planks are delivered with sharp edges (no chamfer)
- Each plank has tongue and groove on all four sides

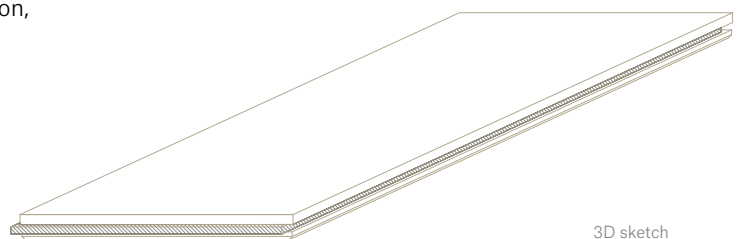

Product range

Layers Douglas is available in one standard dimension; 19 mm thick, 300 mm wide and up to 5 m random lengths.

Planks in random lengths are delivered in available lengths. This makes for a fluid transition from one room to the next and a coherent expression that is perfect for many projects. Each plank is made as long as possible, which makes it possible to use a very high proportion of the raw wood.



Product data and tolerances

Description	Engineered plank in three layers, with a top layer in Douglas. All three layers are made of European douglas fir The top lamella is 6 mm thick and defines the wear layer
Length	2 – 5 m in random lengths
Width	300 mm. Tolerance: +/- 0.3 mm
Thickness	19 mm. Tolerance: +/- 0.2 mm
Right-angled	90 degrees +/- 0.1° degree
Glue	Waterproof and formaldehyde-free
Wood moisture content	7 +/- 1%
Tongue and groove	6 mm
Surface treatment	Unfinished. To be sanded and finished on site
Installation	Installation according to the applicable Dinesen instructions

Technical properties

Hardness (Brinell)	3.29	
Reaction to fire	Dfl-s1	EN 14 342
Thermal resistance	0.15	EN 14 342
Heat conductivity (R)	0.11	EN 14 342
Formaldehyde content	Class E1	EN 14 342
Content of Pentachlorophenol	PCP < 5 ppm	EN 14 342
Density (kg/m³)	470	

Environment and climate

Indoor climate labelling	French VOC Regulation	A+	
	Indoor Air Comfort GOLD®	Passed	
	BREEAM International	Exemplary Level	
	Leed v4.1	Compliant	



Please also see the Declaration of Performance (DOP) and the sorting description, both of which can be found at dinesen.com/technical.

Packaging and weight

The planks are wrapped in airtight plastic packaging.
On-site assistance with regard to unloading is required.

Plank weight approximately: 9 kg/m²

General

About the planks

The planks are supplied unfinished and have a moisture content of 7 +/- 1%. Dinesen floor planks are CE-labelled in accordance with EN 14342.

Delivery times

Delivery times vary and may in some cases be considerable. For more information on delivery time, please contact Dinesen on +45 7455 2140.

Storage

If the floor planks are stored for a short period of time, they must be kept inside in a sealed, dry and warm room. Place the floor planks on joists and wrap them tightly in plastic - also underneath.

Installation

Always consult our [instructions](#) or contact our technical department at technical@dinesen.com or +45 2095 4523.

Please note that the planks must be fully bonded to a structural stable subfloor, with a Dinesen recommended glue system.

Underfloor heating

Suitable for underfloor heating.

Maintenance

We recommend Dinesen products for [finishing and maintenance](#). To preserve the beauty of your Dinesen floor, you need to use Dinesen's maintenance products. We cannot assure the durability and condition of the surface if other products are used.

Webshop

Our webshop with maintenance products and instruction videos can be found at dinesen.com.

Prices

For updated prices, please refer to dinesen.com.

We do not accept any liability for printing errors.